

REVISIONS

REV	DESCRIPTION	DATE	APPROVED
XX	XX	MO/DY/YR	XXX

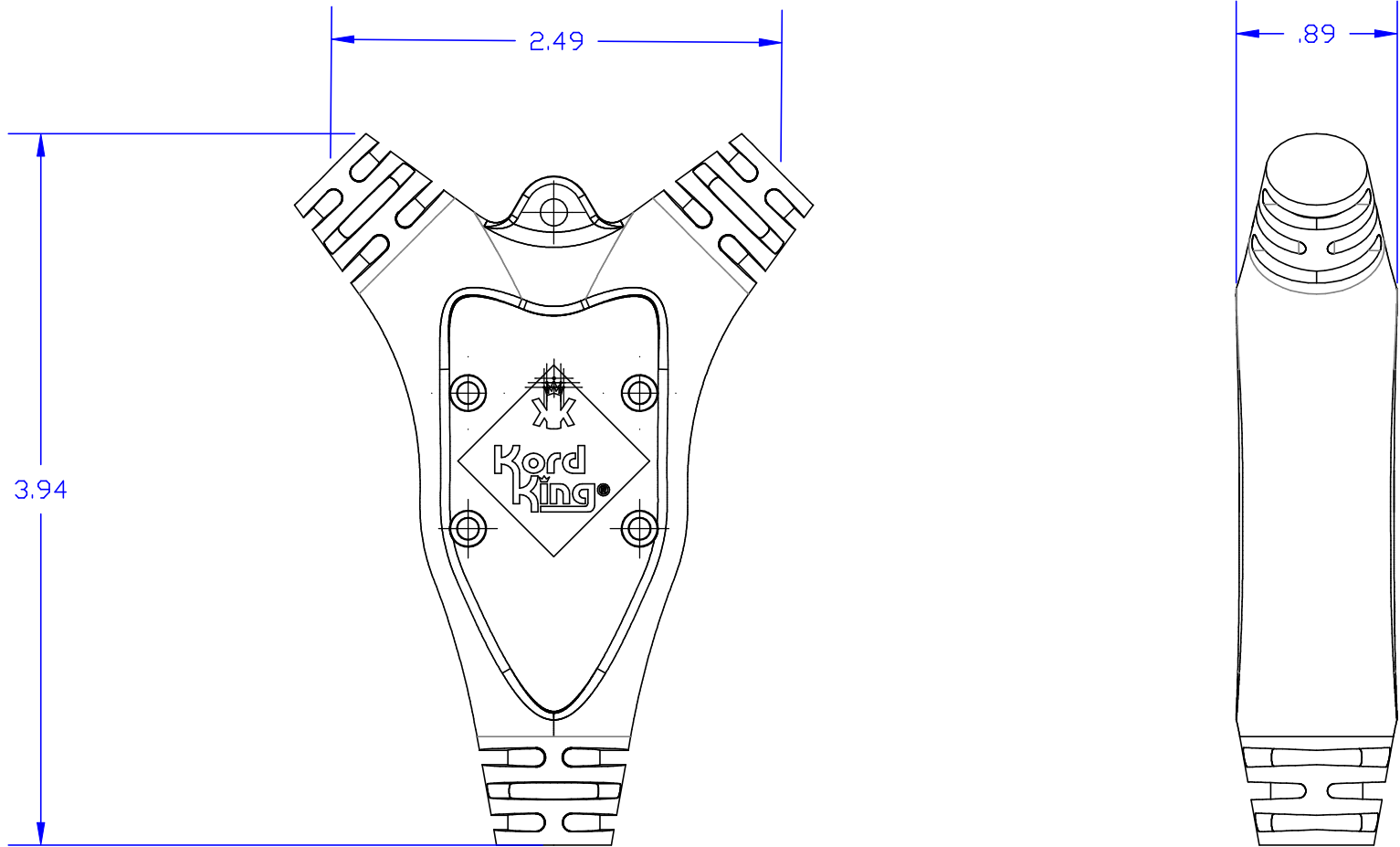

PROPRIETARY INFORMATION
 KORD KING, INC.
 ALL RIGHTS RESERVED

THIS DOCUMENT CONTAINS CONFIDENTIAL AND PROPRIETARY INFORMATION OF KORD KING AND ITS RECEIPT OR POSSESSION DOES NOT CONVEY ANY RIGHTS TO REPRODUCE, DISCLOSE ITS CONTENTS, OR TO MANUFACTURE, USE OR SELL ANYTHING IT MAY DESCRIBE. REPRODUCTION, DISCLOSURE, OR USE WITHOUT SPECIFIC WRITTEN AUTHORIZATION OF KORD KING IS STRICTLY FORBIDDEN.

TOLERANCES
 FRACTIONAL $\pm 1/16$
 2 PLACE DEC. ± 0.030
 3 PLACE DEC. ± 0.015

MATERIAL SPEC
 PLUG: PVC, BLACK
 WIRE: VARIOUS

KORD KING, INC.

YCORD CENTER

SIZE A	FSCM NO.	DWG NO. KK500-Y	REV XX
SCALE NONE	DRAWN BY: AD DATE DWN: 7/30/19	SHEET 1 OF 1	